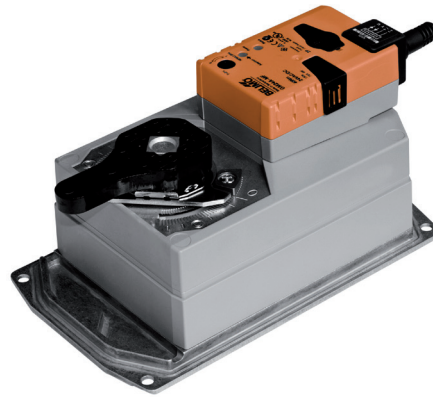

Communicative rotary actuator for butterfly valves

- Nominal torque <90 Nm
- Nominal voltage AC/DC 24 V
- Control Modulating DC (0)2...10 V Variable
- Position feedback DC 2...10 V Variable
- Conversion of sensor signals
- Communication via Belimo MP-Bus

Technical data

Electrical data	Nominal voltage	AC/DC 24 V	
	Nominal voltage frequency	50/60 Hz	
	Nominal voltage range	AC 19.2...28.8 V / DC 21.6...28.8 V	
	Power consumption in operation	9 W	
	Power consumption in rest position	2 W	
	Power consumption for wire sizing	12 VA	
	Connection supply / control	Cable 1 m, 4 x 0.75 mm ²	
	Parallel operation	No	
	Functional data	Torque motor	Max. <90 Nm (not constant)
Positioning signal Y		DC 0...10 V	
Positioning signal Y note		Input impedance 100 kΩ	
Control signal Y variable		Open-close 3-point (AC only) Modulating (DC 0...32 V)	
Operating range Y		DC 2...10 V	
Position feedback U		DC 2...10 V	
Position feedback U note		Max. 0.5 mA	
Position accuracy		±5%	
Manual override		Gear disengagement with push-button, can be locked	
Running time motor		150 s / 90°	
Motor running time variable		75...290 s	
Adaption setting range		manual (automatic on first power-up)	
Adaption setting range variable		No action Adaption when switched on Adaption after pushing the gear disengagement button	
Sound power level motor		45 dB(A)	
Position indication		Mechanically (integrated)	
Safety		Protection class IEC/EN	III Safety extra-low voltage
		Protection class UL	UL Class 2 Supply
	Degree of protection IEC/EN	IP54	
	Degree of protection NEMA/UL	NEMA 2, UL Enclosure Type 2	
	EMC	CE according to 2004/108/EC	
	Certification IEC/EN	IEC/EN 60730-1 and IEC/EN 60730-2-14	
	Certification UL	cULus according to UL 60730-1A, UL 60730-2-14 and CAN/CSA E60730-1:02	
	Mode of operation	Type 1	
	Rated impulse voltage supply / control	0.8 kV	
	Control pollution degree	3	
Mechanical data	Ambient temperature	-30...50°C	
	Non-operating temperature	-40...80°C	
	Ambient humidity	95% r.h., non-condensing	
	Maintenance	Maintenance-free	
	Connection flange	F07	
	Weight	Weight approx.	4.2 kg

Safety notes



- This device has been designed for use in stationary heating, ventilation and air conditioning systems and must not be used outside the specified field of application, especially in aircraft or in any other airborne means of transport.
- Only authorised specialists may carry out installation. All applicable legal or institutional installation regulations must be complied during installation.
- The switch for changing the direction of rotation may not be adjusted.
- The angle of rotation is not permitted to be subjected to mechanical limitation. It is forbidden to alter the mechanical end stops.
- The device may only be opened at the manufacturer's site. It does not contain any parts that can be replaced or repaired by the user.
- Cables must not be removed from the device.
- The device contains electrical and electronic components and must not be disposed of as household refuse. All locally valid regulations and requirements must be observed.

Product features

Principle of operation	<p>Conventional operation: The actuator is connected with a standard modulating signal of DC 0...10V and drives to the position defined by the positioning signal. The measuring voltage U serves for the electrical display of the actuator position 0...100% and as slave control signal for other actuators.</p> <p>Operation on the MP-Bus: The actuator receives its digital positioning signal from the higher level controller via the MP-Bus and drives to the position defined. Connection U serves as communication interface and does not supply an analogue measuring voltage.</p>
Converter for sensors	Connection option for a sensor (passive or active sensor or switching contact). The MP actuator serves as an analogue/digital converter for the transmission of the sensor signal via MP-Bus to the higher level system.
Parameterisable actuators	The factory settings cover the most common applications. Single parameters can be modified with the Belimo Service Tools MFT-P or ZTH EU.
Simple direct mounting	Simple direct mounting on the butterfly valve. The mounting orientation in relation to the butterfly valve can be selected in 90° (angle) increments.
Manual override	Manual override with push-button possible (the gear is disengaged for as long as the button is pressed or remains locked).
High functional reliability	The actuator is overload protected, requires no limit switches and automatically stops when the end stop is reached.
Combination valve/actuator	For valves with the following mechanical specifications in accordance with ISO 5211 F07: <ul style="list-style-type: none"> - Square stem head SW = 17 mm for form-fit coupling of the rotary actuator. - Hole circle d = 70 mm
Home position	The first time the supply voltage is switched on, i.e. at the time of commissioning, the actuator carries out an adaption, which is when the operating range and position feedback adjust themselves to the mechanical setting range. The actuator then moves into the position defined by the positioning signal. Factory setting: Y2 (counter-clockwise rotation).
Adaption and synchronisation	An adaption can be triggered manually by pressing the "Adaption" button or with the PC-Tool. Both mechanical end stops are detected during the adaption (entire setting range). Automatic synchronisation after pressing the gearbox disengagement button is configured. The synchronisation is in the home position (0%). The actuator then moves into the position defined by the positioning signal. A range of settings can be adapted using the PC-Tool (see MFT-P documentation)

Product features

Torque not constant Due to the non linear torque characteristic the actuator can only be used for butterfly valves and not for other armatures.

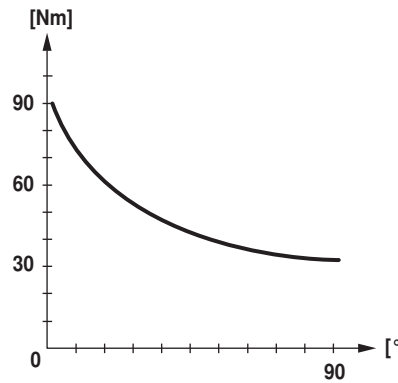

Accessories

	Description	Type
Gateways	Gateway MP for BACnet MS/TP, AC/DC 24 V	UK24BAC
	Gateway MP to Modbus RTU, AC/DC 24 V	UK24MOD
	Gateway MP for LonWorks®, AC/DC 24 V, LonMark-certified	UK24LON
	Gateway MP to KNX/EIB, AC/DC 24 V, EIBA certified	UK24EIB
Electrical accessories	Description	Type
	Connecting cable 5 m, A+B: RJ12 6/6, To ZTH/ZIP-USB-MP	ZK1-GEN
	Connection cable 5 m, A: RJ11 6/4, B: Free wire end, To ZTH/ZIP-USB-MP	ZK2-GEN
	Connecting board MP bus suitable for wiring boxes EXT-WR-FP..-MP	ZFP2-MP
	MP-Bus power supply for MP actuators, AC 230/24V for local power supply	ZN230-24MP
	Auxiliary switch, add-on, 1 x SPDT	S1A
	Auxiliary switch, add-on, 2 x SPDT	S2A
	Feedback potentiometer 140 Ohm, add-on	P140A
	Feedback potentiometer 200 Ohm, add-on	P200A
	Feedback potentiometer 500 Ohm, add-on	P500A
	Feedback potentiometer 1 kOhm, add-on	P1000A
	Feedback potentiometer 2.8 kOhm, add-on	P2800A
	Feedback potentiometer 5 kOhm, add-on	P5000A
Feedback potentiometer 10 kOhm, add-on	P10000A	
Service Tools	Description	Type
	Service Tool, for MF/MP/Modbus/LonWorks actuators and VAV-Controller	ZTH EU
	Belimo PC-Tool, software for adjustments and diagnostics	MFT-P
	Adapter to Service-Tool ZTH	MFT-C
	ZIP-USB-MP interface	ZIP-USB-MP

Electrical installation



Notes

- Connection via safety isolating transformer.
- Direction of rotation switch is covered. Factory setting: Direction of rotation Y2.

Wiring diagrams

AC/DC 24 V, modulating

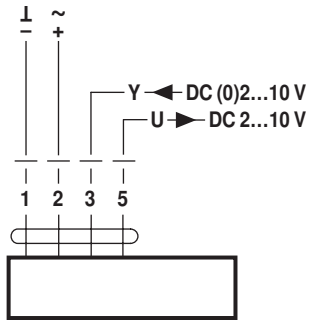

Cable colours:

- 1 = black
- 2 = red
- 3 = white
- 5 = orange

Operation on the MP-Bus

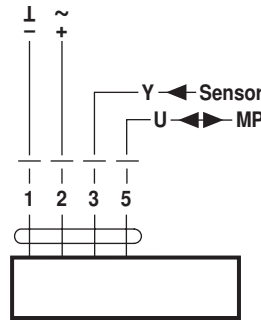

Cable colours:

- 1 = black
- 2 = red
- 3 = white
- 5 = orange

Functions

Functions when operated on MP-Bus

Connection on the MP-Bus

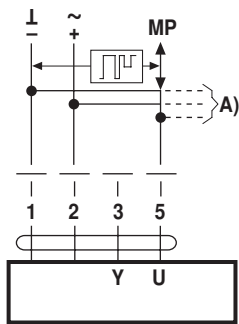

A) more actuators and sensors (max.8)

Network topology

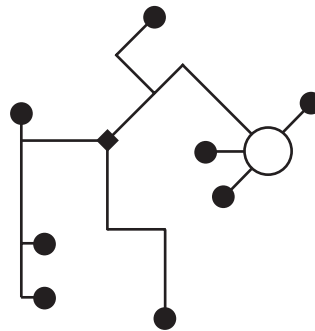

There are no restrictions for the network topology (star, ring, tree or mixed forms are permitted). Supply and communication in one and the same 3-wire cable

- no shielding or twisting necessary
- no terminating resistors required

Connection of active sensors

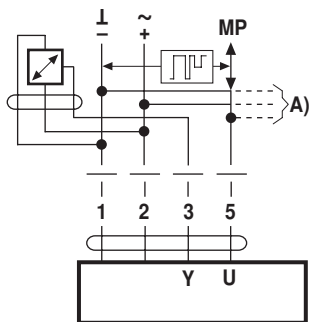

A) more actuators and sensors (max.8)

- Supply AC/DC 24 V
- Output signal DC 0...10 V (max. DC 0...32 V)
- Resolution 30 mV

Connection of external switching contact

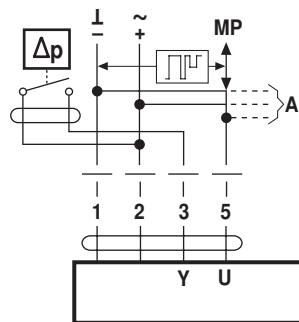

A) more actuators and sensors (max.8)

- Switching current 16 mA @ 24 V
- Start point of the operating range must be parameterised on the MP actuator as ≥ 0.5 V

Connection of passive sensors

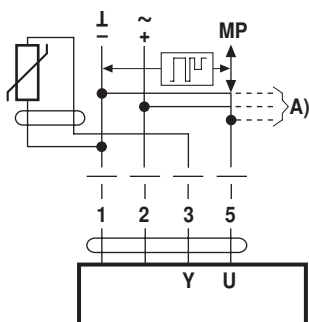

Ni1000	-28...+98 °C	850...1600 Ω^2
PT1000	-35...+155 °C	850...1600 Ω^2
NTC	-10...+160 °C ¹⁾	200 Ω ...60 k Ω^2

A) more actuators and sensors (max.8)

- 1) Depending on the type
- 2) Resolution 1 Ohm

Functions

Functions with basic values (conventional mode)

Override control with AC 24 V with relay contacts

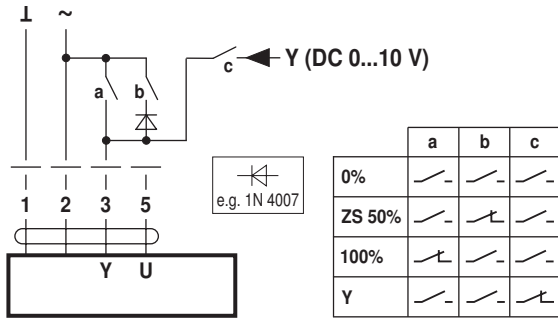

Override control with AC 24 V with rotary switch

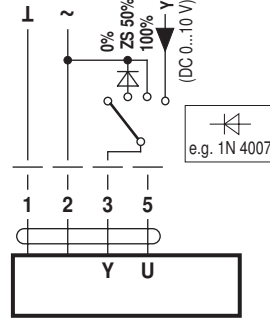

Remote control 0...100% with positioner SG..

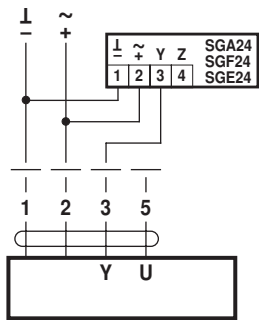

Minimum limit with positioner SG..

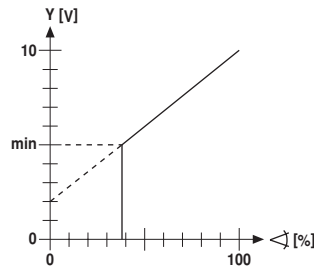
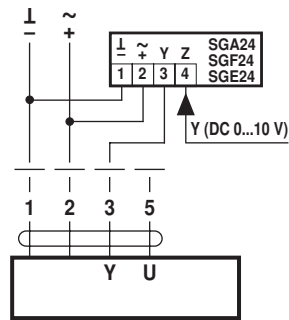

Follow-up control (position-dependent)

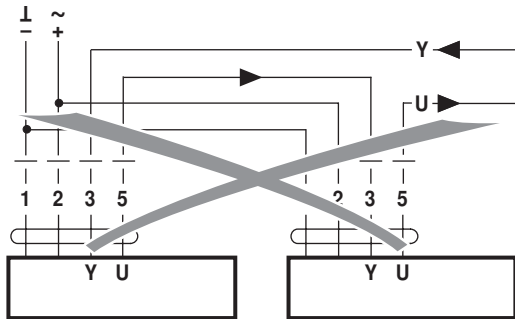

Position indication

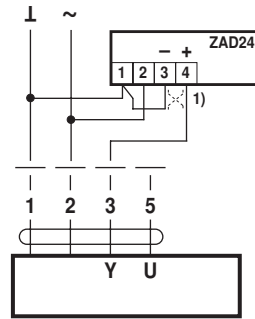

(1) Adapting the direction of rotation

Control with 4...20 mA via external resistor

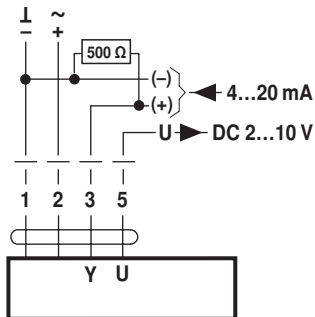

Caution:
The operating range must be set to DC 2...10 V.
The 500 Ω resistor converts the 4...20 mA current signal to a voltage signal DC 2...10 V

Functional check

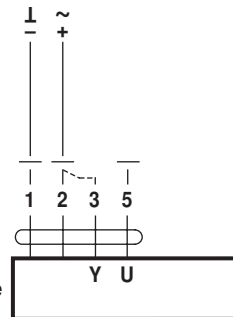

Procedure

1. Connect 24V to connections 1 and 2
2. Disconnect connection 3:
 - with direction of rotation Y1: Actuator rotates to the left
 - with direction of rotation Y2: Actuator rotates to the right
3. Short-circuit connections 2 and 3:
 - Actuator runs in opposite direction

Functions

Functions for actuators with specific parameters (Parametrisation with PC-Tool necessary)

Override control and limiting with AC 24 V with relay contacts

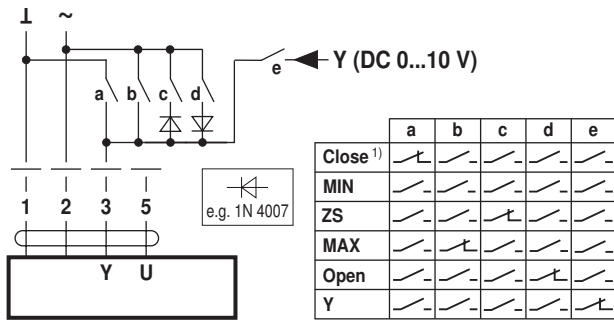

Override control and limiting with AC 24 V with rotary switch

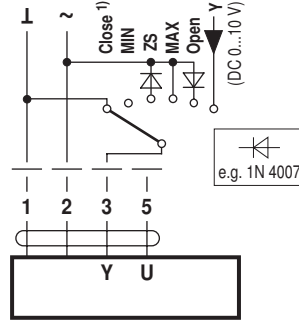

1) **Caution:** This function is only guaranteed if the start point of the operating range is defined as min. 0.5 V.

Control open-close

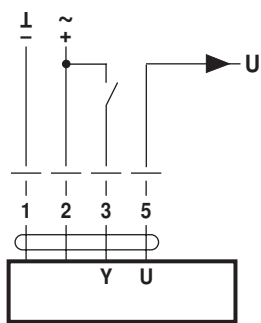

Control 3-point with AC 24 V

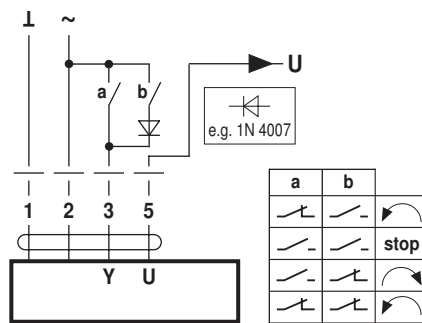

Operating controls and indicators

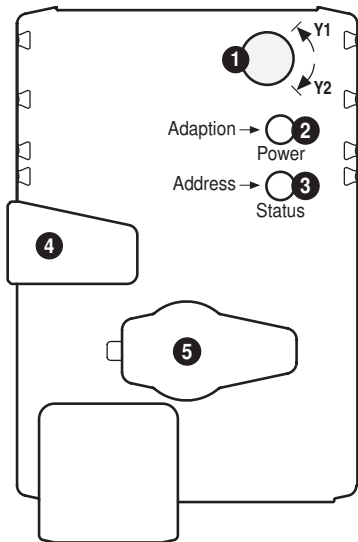

1 Direction of rotation switch

Switch over: Direction of rotation changes

2 Push-button and LED display green

Off: No power supply or malfunction
 On: In operation
 Press button: Triggers angle of rotation adaptation, followed by standard mode

3 Push-button and LED display yellow

Off: Standard mode
 Flickering: MP communication active
 On: Adaptation or synchronising process active
 Flashing: Request for addressing from MP master
 Press button: Confirmation of the addressing

4 Gear disengagement button

Press button: Gear disengages, motor stops, manual override possible
 Release button: Gear engages, synchronisation starts, followed by standard mode

5 Service plug

For connecting parameterisation and service tools

Check power supply connection

2 Off and **3** On Possible wiring error in power supply

Service



Notes

- The actuator can be parameterised by PC-Tool and ZTH EU via the service socket.

ZTH EU connection

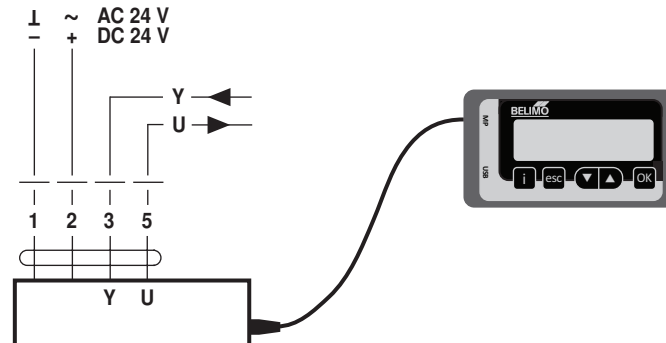

PC-Tool connection

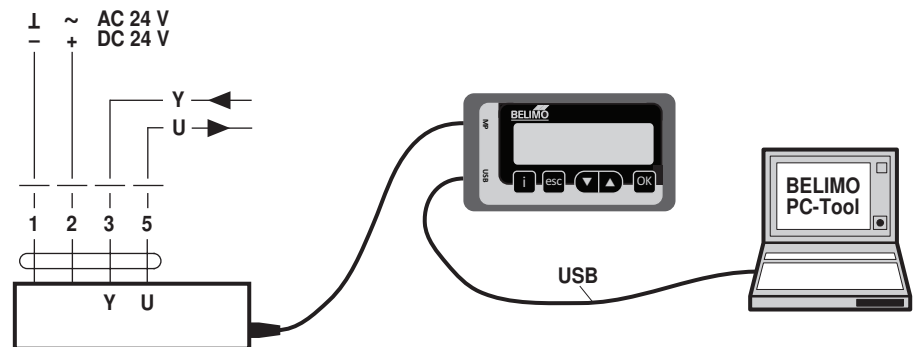

Dimensions [mm]

Dimensional drawings

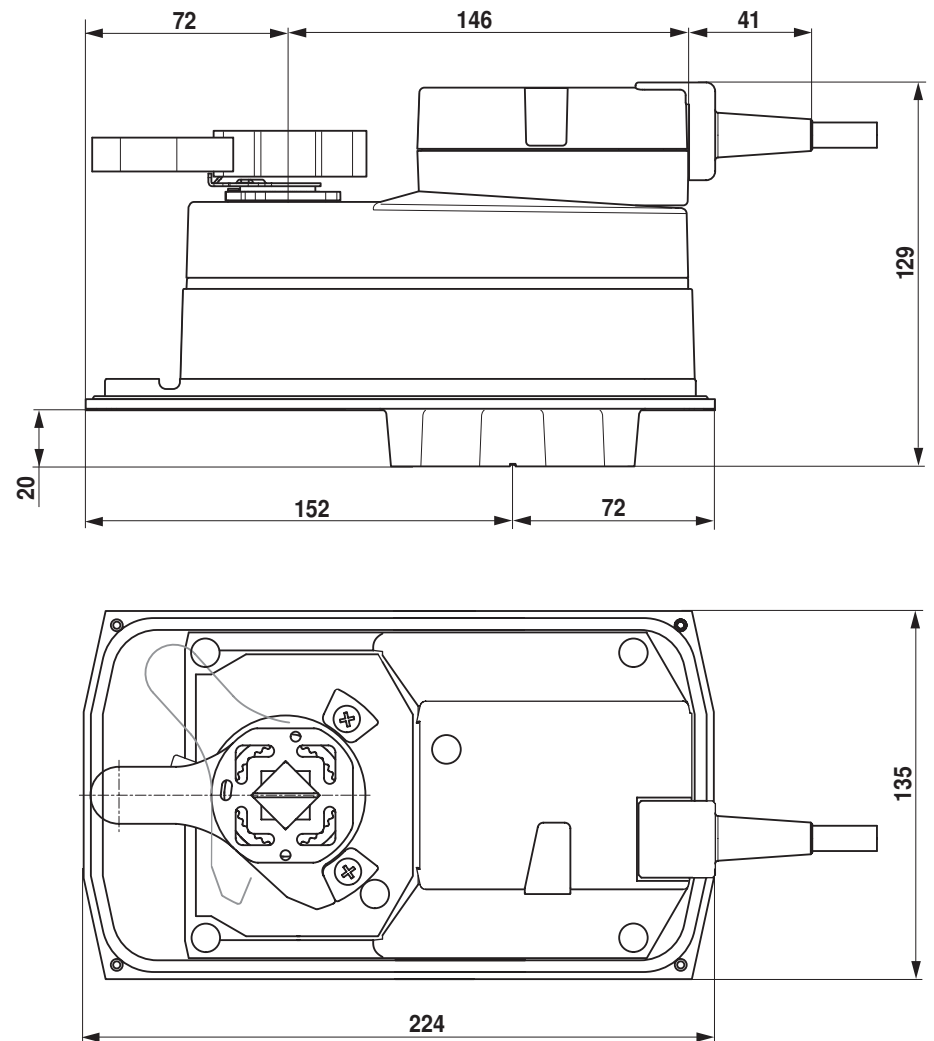

Further documentation

- Overview MP Cooperation Partners
- Tool Connection Guide