

Parameterisable RobustLine SuperCap rotary actuator with emergency control function and extended functionalities for adjusting dampers in technical building installations and laboratories.

- Air damper size up to approx. 1.2 m²
- Nominal torque 6 Nm
- Nominal voltage AC/DC 24 V
- Control Modulating DC (0)2...10 V Variable
- Position feedback DC 2...10 V Variable
- Running time motor 4 s Variable
- Design life SuperCaps: 15 years
- Optimum protection against corrosion and chemical influences, UV radiation, damp and condensation

Technical data

Electrical data	Nominal voltage	AC/DC 24 V
	Nominal voltage frequency	50/60 Hz
	Nominal voltage range	AC 19.2...28.8 V / DC 21.6...28.8 V
	Power consumption in operation	11 W
	Power consumption in rest position	3 W
	Power consumption for wire sizing	22 VA
	Power consumption for wire sizing note	I _{max} 20 A @ 5 ms
	Connection supply / control	Cable 1 m, 4 x 0.75 mm ² (halogen-free)
Parallel operation	Yes (note the performance data)	
Functional data	Torque motor	Min. 6 Nm
	Positioning signal Y	DC 0...10 V
	Positioning signal Y note	Input impedance 100 kΩ
	Control signal Y variable	Open-close Modulating (DC 0...32 V)
	Operating range Y	DC 2...10 V
	Operating range Y variable	Start point DC 0.5...30 V End point DC 2.5...32 V
	Position feedback U	DC 2...10 V
	Position feedback U note	Max. 0.5 mA
	Position feedback U variable	Start point DC 0.5...8 V End point DC 2.5...10 V
	Emergency setting position (POP)	0%, adjustable in increments of 10% (POP rotary knob on 0 corresponds to left end stop)
	Emergency setting position variable	0...100%, adjustable
	Bridging time (PF)	0 s
	Bridging time (PF) variable	0...5 s
	Position accuracy	±5%
	Direction of motion motor	Selectable with switch 0 / 1
	Direction of motion emergency control function	Selectable with switch 0...100%
	Direction of motion note	Y = 0 V: At switch position 0 (ccw rotation) / 1 (cw rotation)
	Direction of motion variable	Electronically reversible
	Manual override	Gear disengagement with push-button
	Angle of rotation	Max. 95°
	Angle of rotation note	can be limited on both sides with adjustable mechanical end stops
	Minimum angle of rotation	Min. 30°
	Running time motor	4 s / 90°
Motor running time variable	4...20 s	
Running time emergency control position	4 s / 90°	
Adaption setting range	manual (automatic on first power-up)	
Adaption setting range variable	No action Adaption when switched on Adaption after pushing the gear disengagement button	

Technical data

Functional data	Override control	MAX (maximum position) = 100% MIN (minimum position) = 0% ZS (intermediate position, AC only) = 50%	
	Override control variable	MAX = (MIN + 32%)...100% MIN = 0%...(MAX - 32%) ZS = MIN...MAX	
	Sound power level motor	60 dB(A)	
	Sound power level emergency control position	60 dB(A)	
	Spindle driver	Universal spindle clamp 10...20 mm	
	Position indication	Mechanically, pluggable	
	Safety	Protection class IEC/EN	III Safety extra-low voltage
		Protection class UL	UL Class 2 Supply
		Degree of protection IEC/EN	IP66 + IP67
		Degree of protection NEMA/UL	NEMA 4, UL Enclosure Type 4
EMC		CE according to 2004/108/EC	
Certification IEC/EN		IEC/EN 60730-1 and IEC/EN 60730-2-14	
Certification UL		cULus according to UL 60730-1A, UL 60730-2-14 and CAN/CSA E60730-1:02	
Mode of operation		Type 1.AA	
Rated impulse voltage supply / control		0.8 kV	
Control pollution degree		4	
Ambient temperature	-30...50 °C		
Non-operating temperature	-40...80 °C		
Ambient humidity	100% r.h.		
Maintenance	Maintenance-free		
Weight	Weight approx.	2.3 kg	
Terms	Abbreviations	POP = Power off position / emergency setting position CPO = Controlled power off / controlled emergency control function PF = Power fail delay time / bridging time	

Safety notes



- The device must not be used outside the specified field of application, especially not in aircraft or in any other airborne means of transport.
- Only authorised specialists may carry out installation. All applicable legal or institutional installation regulations must be complied during installation.
- Junction boxes must at least correspond with enclosure IP degree of protection!
- The cover of the protective housing may be opened for adjustment and servicing. When it is closed afterwards, the housing must seal tight (see installation instructions).
- The device on the inside may only be opened in the manufacturer's factory. It does not contain any parts that can be replaced or repaired by the user.
- The cables must not be removed from the device installed in the interior.
- When calculating the torque required, the specifications supplied by the damper manufacturers (cross-section, construction, place of installation), and the ventilation conditions must be observed.
- The device contains electrical and electronic components and is not allowed to be disposed of as household refuse. All locally valid regulations and requirements must be observed.
- The information on chemical resistance refers to laboratory tests with raw materials and finished products and to trials in the field in the areas of application indicated.
- The materials used may be subjected to external influences (temperature, pressure, constructional fixture, effect of chemical substances, etc.), which cannot be simulated in laboratory tests or field trials.

Safety notes

- The information regarding areas of application and resistance can therefore only serve as a guideline. In case of doubt, we definitely recommend that you carry out a test. This information does not imply any legal entitlement. Belimo will not be held liable and will provide no warranty. The chemical or mechanical resistance of the materials used is not alone sufficient for judging the suitability of a product. Regulations pertaining to combustible liquids such as solvents etc. must be taken into account with special reference to explosion protection.

Product features

Fields of application	The actuator is particularly suitable for utilisation in outdoor applications and is protected against the following weather conditions: <ul style="list-style-type: none"> - Wood drying - Animal breeding - Food processing - Agricultural - Swimming baths / bathrooms - Rooftop ventilation plant rooms - General outdoor applications - Changing atmosphere - Laboratories
Resistances	Noxious gas test EN 60068-2-60 (Fraunhofer Institut ICT / DE) Salt fog spray test EN 60068-2-52 (Fraunhofer Institut ICT / DE) Ammoniac test DIN 50916-2 (Fraunhofer Institut ICT / DE) Climate test IEC60068-2-30 (Trikon Solutions AG / CH) Disinfectant (animals) (Trikon Solutions AG / CH) UV Test (Solar radiation at ground level) EN 60068-2-5, EN 60068-2-63 (Quinel / Zug CH)
Used materials	Actuator housing polypropylene (PP) Cable glands / hollow shaft polyamide (PA) Connecting cable FRNC Clamp / screws in general Steel 1.4404 Seals EPDM Form fit insert aluminium anodised
Mode of operation	The actuator moves the damper to the desired operating position at the same time as the integrated capacitors are charged. Interrupting the supply voltage causes the damper to be rotated back into the emergency setting position (POP) by means of stored electrical energy. The actuator is connected with a standard modulating signal of DC 0 ... 10V and travels to the position defined by the positioning signal. Measuring voltage U serves for the electrical display of the damper position 0 ... 100% and as slave control signal for other actuators.

Product features

Pre-charging time (start up) The capacitor actuators require a pre-charging time. This time is used for charging the capacitors up to a usable voltage level. This ensures that, in the event of an electricity interruption, the actuator can move at any time from its current position into the preset emergency setting position (POP).

The duration of the pre-charging time depends mainly on following factors:

- Duration of the electricity interruption
- PF delay time (bridging time)

Typical pre-charging time

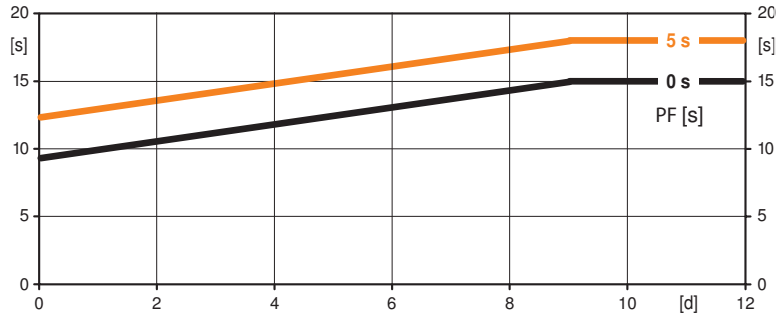

[d] = Electricity interruption in days
[s] = Pre-charging time in seconds

PF[s] = Bridging time

Calculation example: Given an electricity interruption of 3 days and a bridging time (PF) set at 5 s, the actuator requires a pre-charging time of 14 s after the electricity has been reconnected (see graphic).

PF [s]	[d]				
	0	1	2	7	≥10
0	9	10	11	13	15
5	12	13	14	16	18
	[s]				

Delivery condition (capacitors) The actuator is completely discharged after delivery from the factory, which is why the actuator requires approximately 20 s pre-charging time before initial commissioning in order to bring the capacitors up to the required voltage level.

Parameterisable actuators The factory settings cover the most common applications. Input and output signals and other parameters can be altered with the PC-Tool MFT-P or with the Service tool ZTH EU.

Direct mounting Simple direct mounting on the damper spindle with a universal spindle clamp, supplied with a universal mounting bracket to prevent the actuator from rotating.

Manual override Manual control with push-button possible - temporary. The gear is disengaged and the actuator decoupled for as long as the button is pressed.

High functional reliability The actuator is overload protected, requires no limit switches and automatically stops when the end stop is reached.

Adjustable angle of rotation Adjustable angle of rotation with mechanical end stops. A minimum permissible angle of rotation of 30° must be allowed for.

Home position The first time the supply voltage is switched on, i.e. at the time of commissioning, the actuator carries out an adaption, which is when the operating range and position feedback adjust themselves to the mechanical setting range. The detection of the mechanical end stops enables a gentle approach to the end positions, thus protecting the actuator mechanics. The actuator then moves into the position defined by the positioning signal.

Direction of rotation switch When actuated, the direction of rotation switch changes the running direction in normal operation. The direction of rotation switch has no influence on the emergency setting position (POP) which has been set.

Adaption and synchronisation An adaption can be triggered manually by pressing the „Adaption“ button or with the PC-Tool. Both mechanical end stops are detected during the adaption (entire setting range).

Automatic synchronisation after pressing the gearbox disengagement button is configured. The synchronisation is in the home position (0%).

The actuator then moves into the position defined by the positioning signal.

A range of settings can be adapted using the PC-Tool (see MFT-P documentation)

Product features

Rotary knob emergency setting position

The «Emergency setting position» rotary knob can be used to adjust the desired emergency setting position (POP) between 0 and 100% in 10% increments. The rotary knob is in reference only to the adapted angle of rotation range between 30 and 95°. No set Min or Max values are observed. In the event of a electricity interruption, the actuator will move into the selected emergency setting position, taking into account the bridging time that has been set. Settings: The rotary knob must be set to the «Tool» position for retroactive settings of the emergency setting position with the BELIMO service tool MFT-P. Once the rotary knob is set back to the range 0...100%, the manually set value will have positioning authority

Bridging time (PF)

The «Emergency setting position» rotary knob can be used to adjust the desired emergency setting position (POP). In the event of an electricity interruption, the actuator will move into the selected emergency setting position, taking into account the bridging time (PF) of 2 s which was set ex-works. Settings: The rotary knob must not be set to the «Tool» position! Only the values need to be entered for retroactive adjustments of the bridging time with the BELIMO service tool MFT-P.

Accessories

	Description	Type
Electrical accessories	Connecting cable 5 m, A+B: RJ12 6/6, To ZTH/ZIP-USB-MP	ZK1-GEN
	Connection cable 5 m, A: RJ11 6/4, B: Free wire end, To ZTH/ZIP-USB-MP	ZK2-GEN
Service Tools	Description	Type
	Service Tool, for MF/MP/Modbus/LonWorks actuators and VAV-Controller	ZTH EU
	Belimo PC-Tool, software for adjustments and diagnostics	MFT-P
	Adapter to Service-Tool ZTH	MFT-C

Electrical installation



Notes

- Connection via safety isolating transformer.
- Parallel connection of other actuators possible. Observe the performance data.

Wiring diagrams

AC/DC 24 V, modulating

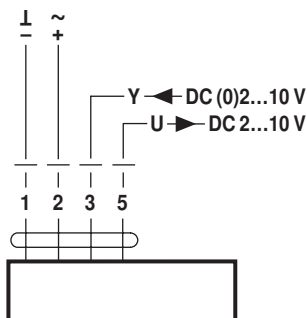

Electrical installation

Parallel operation

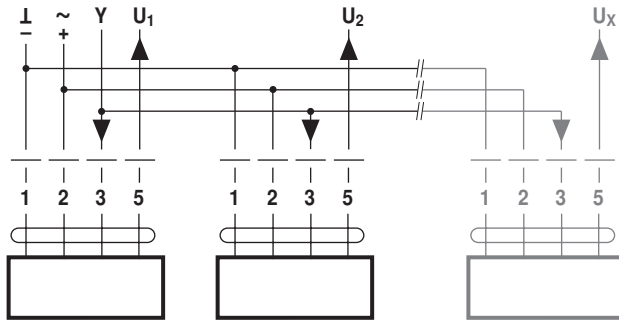

Notes

- A maximum of eight actuators can be connected in parallel.
- Parallel operation is permitted only on non-connected axes.
- Do not fail to observe performance data with parallel operation.

Signal cable lengths

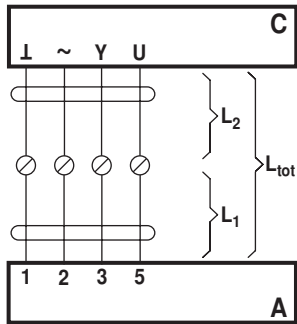

L ₂ ┓ / ~	L _{tot} = L ₁ + L ₂	
	AC	DC
0.75 mm ²	≤30 m	≤5 m
1.00 mm ²	≤40 m	≤8 m
1.50 mm ²	≤70 m	≤12 m
2.50 mm ²	≤100 m	≤20 m

A = actuator

C = control unit

L1 = actuator connecting cable

L2 = customer cable

Ltot = maximum signal cable length

Note:

In the event of several actuators switched in parallel, the maximum signal cable length is to be divided by the number of actuators.

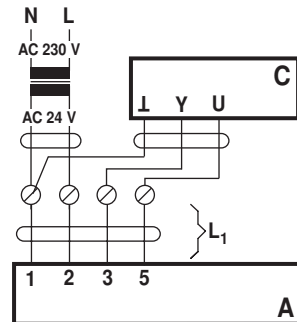

A = actuator

C = control unit

L1 = actuator connecting cable

Note:

If supply and data line are handled separately, then no special limitations apply for the installation.

Functions

Functions with basic values (conventional mode)

Override control with AC 24 V with relay contacts

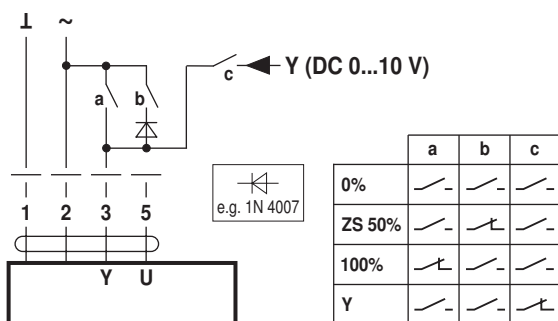

Override control with AC 24 V with rotary switch

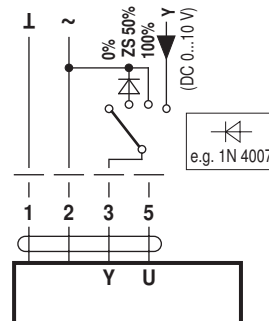

Functions

Remote control 0...100% with positioner SG.. Minimum limit with positioner SG..

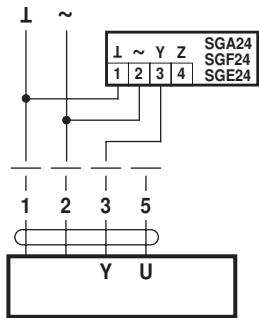

Position indication

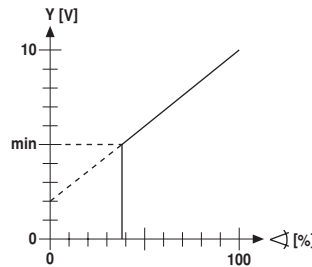
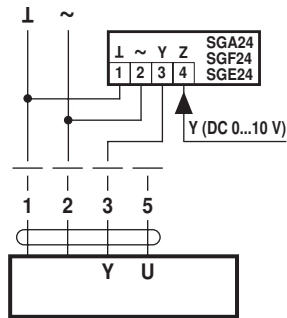

Control with 4...20 mA via external resistor

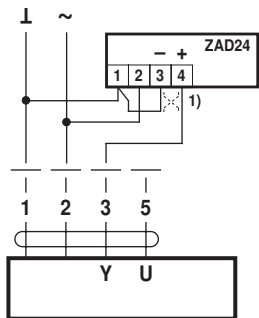

Functional check

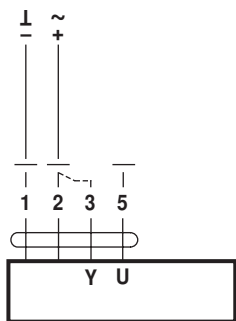

Procedure

1. Connect 24V to connections 1 and 2
2. Disconnect connection 3:
 - with direction of rotation 0: Actuator rotates to the left
 - with direction of rotation 1: Actuator rotates to the right
3. Short-circuit connections 2 and 3:
 - Actuator runs in opposite direction

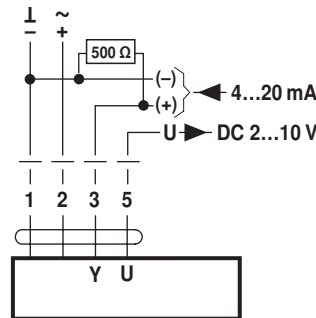

Caution:

The operating range must be set to DC 2...10 V.
The 500 Ω resistor converts the 4...20 mA current signal to a voltage signal DC 2...10 V

Functions for actuators with specific parameters (Parametrisation with PC-Tool necessary)

Override control and limiting with AC 24 V with relay contacts

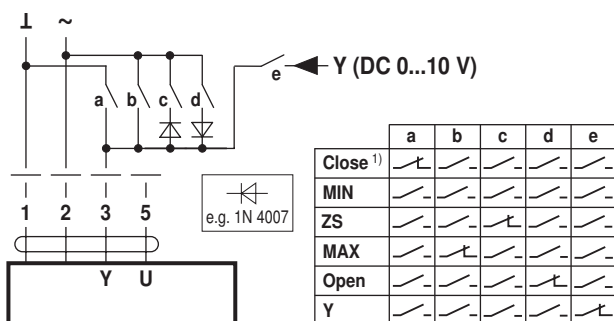

Override control and limiting with AC 24 V with rotary switch

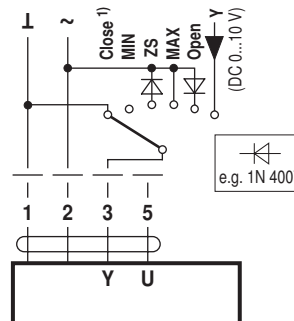

1) **Caution:** This function is only guaranteed if the start point of the operating range is defined as min. 0.5 V.

Functions

Control open-close

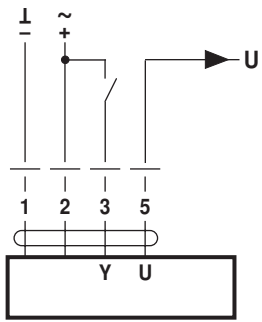

Control 3-point

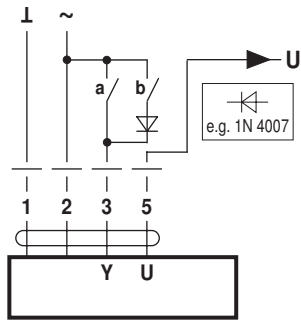

Operating controls and indicators

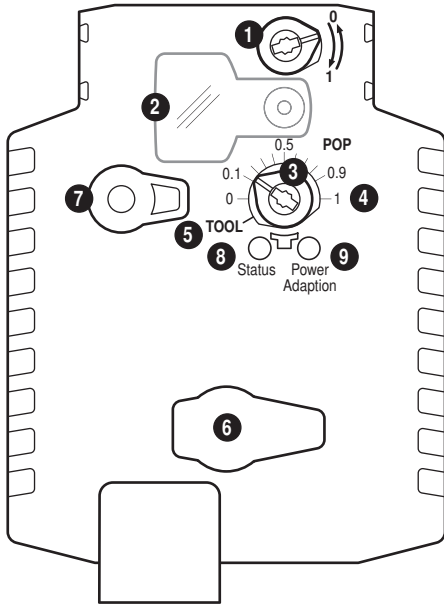

- 1 Direction of rotation switch
- 2 Cover, POP button
- 3 POP button
- 4 Scale for manual adjustment
- 5 Position for adjustment with tool
- 6 Tool socket
- 7 Disengagement button

LED displays		Meaning / function
8 yellow	9 green	
Off	On	Operation OK / without fault
Off	Flashing	POP function active
On	Off	Fault
Off	Off	Not in operation
On	On	Adaptation procedure running
Flashing	On	Communication with programming tool

- 9 **Press button:** Triggers angle of rotation adaption, followed by standard operation

Emergency position (POP) setting

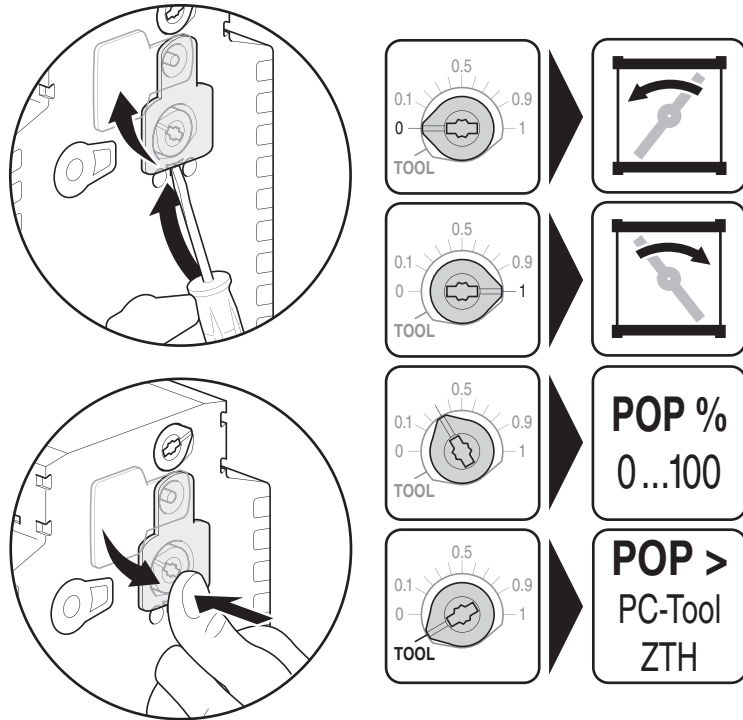

Service



Notes

- The actuator can be parameterised by PC-Tool and ZTH EU via the service socket.

ZTH EU connection

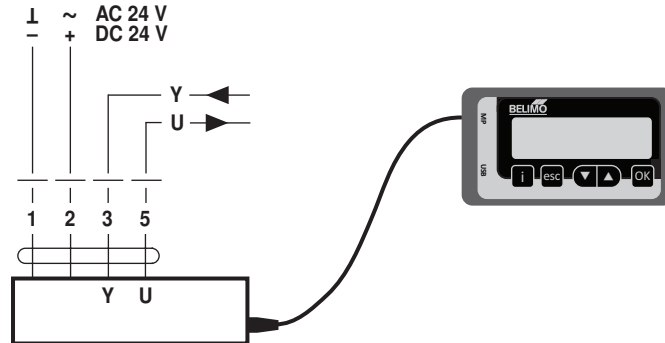

PC-Tool connection

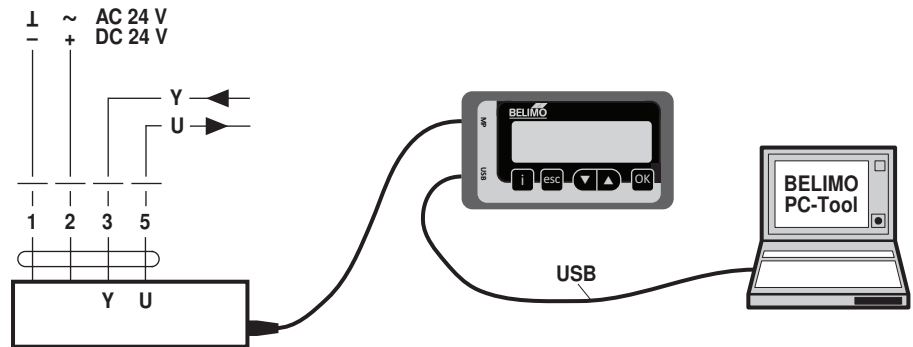

Dimensions [mm]

Spindle length

		20...58
		-

Clamping range

8...20	8...14	10...20

Dimensional drawings

