

Modulating SuperCap rotary actuator with emergency setting function and extended functionalities in the IP66 protective housing for adjusting air dampers in ventilation and air-conditioning systems for building services installations and in laboratories

- For air dampers up to approx. 8 m²
- Torque 40 Nm
- Nominal voltage AC/DC 24 V
- Control: modulating DC 0 ... 10 V
- Position feedback DC 2 ... 10 V
- Design life SuperCaps 15 years

Optimum weather protection (for use in ambient temperatures up to -40°C, there is a separate actuator available with built-in heater ex works)

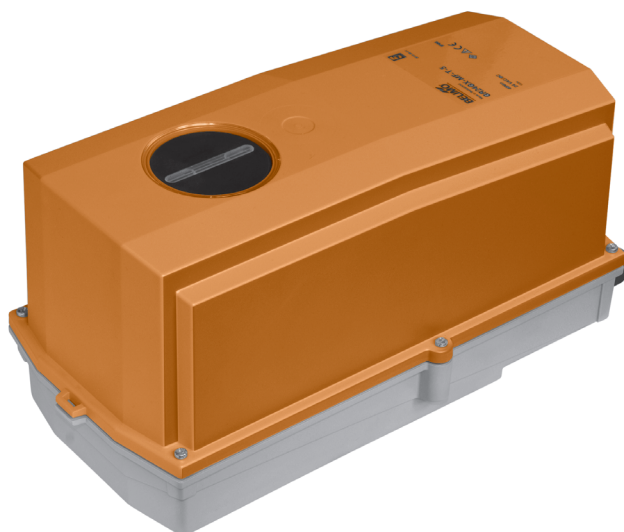

Technical data

Electrical data	Nominal voltage	AC 24 V, 50/60 Hz / DC 24 V	
	Nominal voltage range	AC 19.2 ... 28.8 V / DC 21.6 ... 28.8 V	
	Power consumption	In operation	11 W @ nominal torque
		At rest	3 W
	For wire sizing	21 VA (I _{max} 20 A @ 5 ms)	
	Connection	Cable 1 m, 4 x 0.75 mm ² (halogen-free)	
	Parallel operation	Yes (note the performance data)	
Functional data	Torque	≥40 Nm	
	Inhibiting torque	≥40 Nm	
	Control	Control signal Y	DC 0 ... 10 V, input impedance 100 kΩ
		Operating range	DC 2 ... 10 V
	Position feedback (Measuring voltage U)	DC 2 ... 10 V, max. 0.5 mA	
	Setting emergency position (POP)	0...100%, adjustable (POP rotary button)	
	Position accuracy	±5%	
	Direction of rotation	Motor	As an option with switch ↺ / ↻
		Emergency setting position	Reversible with switch 0 ... 100%
	Direction of rotation Y = 0 V		At switch position 1 ↺ and 0 ↻, respectively
	Manual override		Gearing latch disengaged with push button
	Angle of rotation		Max. 95°↔, can be limited at both ends with adjustable mechanical end stops
	Running time	Motor	150 s / 90°↔
		Emergency setting position	35 s @ 0 ... 50°C
Sound power level	Motor	≤53 dB (A) @ 90 s running time	
		≤52 dB (A) @ 150 s running time	
	Emergency setting position	≤61 dB (A)	
	Position indication	Mechanical, pluggable	
Safety	Protection class	III Safety extra-low voltage UL Class 2 Supply	
	Degree of protection	IP66 NEMA 4, UL Enclosure Type 4	
	EMC	CE according to 2004/108/EC	
	Certification	Certified to IEC/EN 60730-1 and IEC/EN 60730-2-14 cULus according to UL 60730-1A and UL 60730-2-14 and CAN/CSA E60730-1:02	
	Mode of operation	Type 1.AA	
	Rated impulse voltage	0.8 kV	
	Control pollution degree	4	

Terms and abbreviations POP = Power off position / emergency setting position
PF = Power fail delay time / bridging time

Technical data
(continued)

Safety	Ambient temperature	-30 ... +50 °C (actuator with built-in heater -40 ... +50 °C)
	Non-operating temperature	-40 ... +80 °C
	Ambient humidity	100% r.h.
	Maintenance	Maintenance-free
Dimensions / Weight	Dimensions	See «Dimensions» on page 6
	Weight	Approx. 4.8 kg

Safety notes

- The actuator is not allowed to be used outside the specified field of application, especially in aircraft or in any other airborne means of transport.
- It may only be installed by suitably trained personnel. Any legal regulations or regulations issued by authorities must be observed during installation.
- The cover of the protective housing may be opened for adjustment and servicing. When it is closed afterwards, the housing must seal tight (see installation instructions).
- The device on the inside may only be opened up in the factory. It does not contain any parts that can be replaced or repaired by the user.
- The cable must not be removed from the device on the inside.
- When calculating the required torque, the specifications supplied by the damper manufacturers (cross-section, design, installation site), and the air flow conditions must be observed.
- The device contains electrical and electronic components and is not allowed to be disposed of as household refuse. All locally valid regulations and requirements must be observed.
- The actuator is not designed for applications where chemical influences (gases, fluids) are present or for utilisation in corrosive environments in general.
- The materials used may be subjected to external influences (temperature, pressure, constructional fixture, effect of chemical substances, etc.), which cannot be simulated in laboratory tests or field trials.
In case of doubt, we definitely recommend that you carry out a test. This information does not imply any legal entitlement. Belimo will not be held liable and will provide no warranty.
- For UL (NEMA) Type 4 applications flexible metallic cable conduits or threaded cable conduits of equal value are to be used.
- The actuator may not be used in plenum applications (e.g. suspended ceilings or raised floors).

Product features

Fields of application	The actuator is particularly suitable for utilisation in outdoor applications and is protected against the following weather conditions: <ul style="list-style-type: none"> – UV radiation – rain / snow – dirt / dust – humidity – Changing atmosphere / frequent and severe temperature fluctuations (recommendation: use the actuator with integrated factory-installed heating which can be ordered separately to prevent internal condensation)
Mode of operation	The actuator moves the air damper to the desired operating position at the same time as the integrated capacitors are loaded . Interrupting the supply voltage causes the air damper to be rotated back into the emergency setting position by means of stored electrical energy. The actuator is controlled with a standard modulating signal of DC 0 ... 10 V and travels to the position defined by the control signal. The measuring voltage U serves for the electrical display of the damper position 0 ... 100%.

Product features

(continued)

Pre-charging time (start up) The capacitor actuators require a pre-charging time. This time is used for charging the capacitors up to a usable voltage level. This ensures that, in the event of a voltage interruption, the actuator can be moved at any time from its current position into the preset emergency setting position (POP).
The duration of the pre-charging time depends mainly on how long the power was interrupted.

Typical pre-charging times

Pre-charging time [s]	Duration of voltage interruption [Days]				
	0	1	2	7	≥10
	6	9	11	16	20

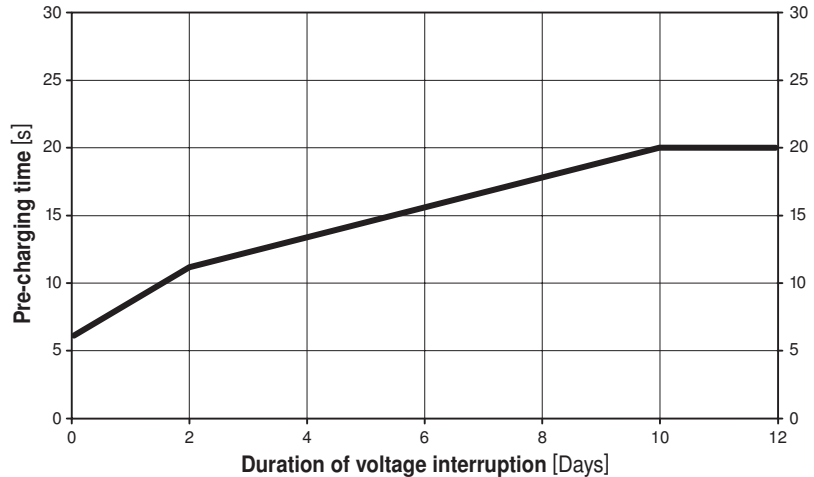

- Delivery condition (capacitors)** The actuator is completely discharged after delivery from the factory, which is why the actuator requires approximately 20 s pre-charging time before initial commissioning in order to bring the capacitors up to the required voltage level.
- Simple direct mounting** Simple direct mounting on the damper spindle with a universal spindle clamp, supplied with an anti-rotation strap to prevent the actuator from rotating.
- Manual override** Manual override with push button possible (the gear is disengaged for as long as the button remains pressed down).
- High operational reliability** The actuator is overload-proof, requires no limit switches and automatically stops when the end stop is reached.
- Home position / Start** The clamp of the actuator is set ex-works to 0°↙. After the supply voltage has been applied, the actuator moves into the position defined by the control signal.
- Direction of rotation switch** When actuated, the direction of rotation switch changes the running direction in normal operation.
The direction of rotation switch has no influence on the emergency setting position (POP) which has been set.
- Emergency setting position (POP) rotary button** The «Emergency setting position» rotary button can be used to adjust the desired emergency setting position (POP) between 0 and 100% in 10% increments.
The rotary button always refers to an angle of rotation of 95°↙ and does not take into account any retroactively adjusted end stops.
In the event of a voltage interruption, the actuator will move into the selected emergency setting position, taking into account the bridging time (PF) of 2 s which was set ex-works.

Accessories

	Description	Data sheet
Electrical accessories	Auxiliary switch S..A..	T2 - S..A..
	Feedback potentiometer P..A..	T2 - P..A..
	Position sensor SGA24, SGE24 and SGF24	T2 - SG..24
	Digital position indication ZAD24	T2 - ZAD24
	Room temperature controller CR24..	S4 - CR24..
	Heating with mechanical hygrostat HH24-MG *	T2/T5 - HH24-MG
	Heating with mechanical thermostat HT24-MG *	T2/T5 - HT24-MG

* only available fitted in separate actuator

Electrical installation

Wiring diagram

Note
Connect via safety isolation transformer.

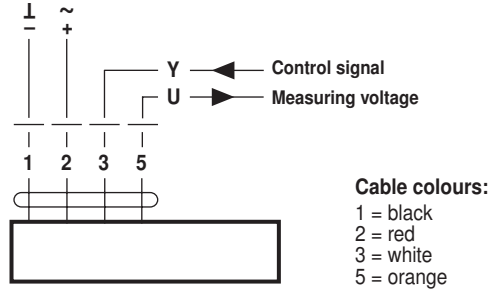

Cable colours:
1 = black
2 = red
3 = white
5 = orange

Wiring diagram for parallel operation

Notes

- A maximum of eight actuators can be connected in parallel.
- Parallel operation is permitted only on separated axes.
- It is imperative that the performance data be observed with parallel operation.

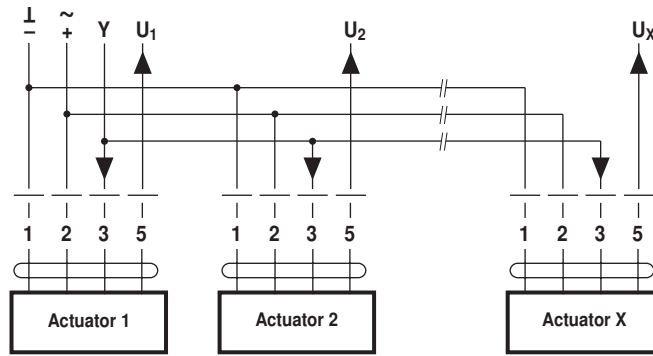

Cable lengths

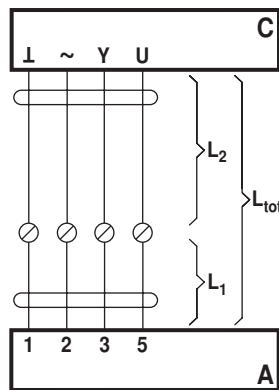

A = Actuator
C = Control unit
L₁ = Belimo connecting cable, 1 m (4 x 0.75 mm²)
L₂ = Customer cable
L_{tot} = Maximum cable length

Cross-section L ₂	Max. cable length L _{tot} = L ₁ + L ₂		Example for DC
	AC	DC	
0.75 mm ²	≤40 m	≤20 m	1 m (L ₁) + 19 m (L ₂)
1.00 mm ²	≤50 m	≤30 m	1 m (L ₁) + 29 m (L ₂)
1.50 mm ²	≤80 m	≤45 m	1 m (L ₁) + 44 m (L ₂)
2.50 mm ²	≤130 m	≤80 m	1 m (L ₁) + 79 m (L ₂)

Note
When several actuators are connected in parallel, the maximum cable length must be divided by the number of actuators.

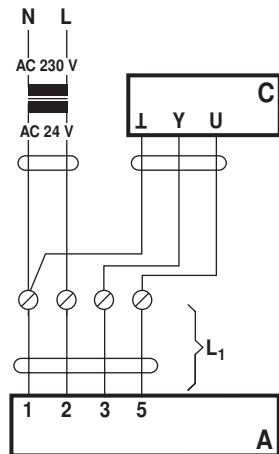

A = Actuator
C = Control unit
L₁ = Belimo connecting cable, 1 m (4 x 0.75 mm²)

Note
There are no special restrictions on installation if the supply and data cable are routed separately.

Operating controls and indicators

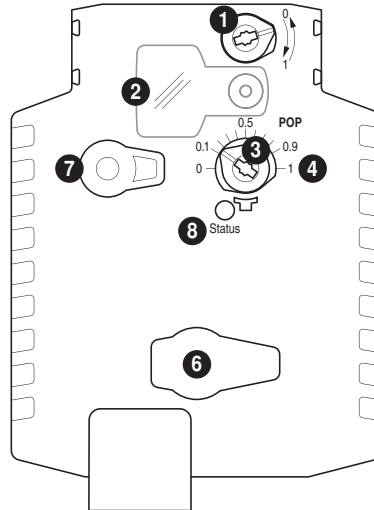
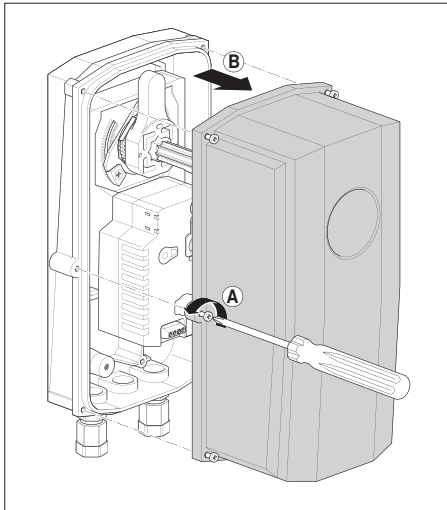

- 1 Direction of rotation switch
- 2 Cover, POP button
- 3 POP button
- 4 Scale for manual adjustment
- 6 (no function)
- 7 Disengagement button

LED display	Meaning / function
8 green	
Illuminated	Operation OK / without fault
Blinking	POP function active
Off	- Not in operation - Pre-charging time SuperCap - Fault SuperCap

Setting the POP Power off position

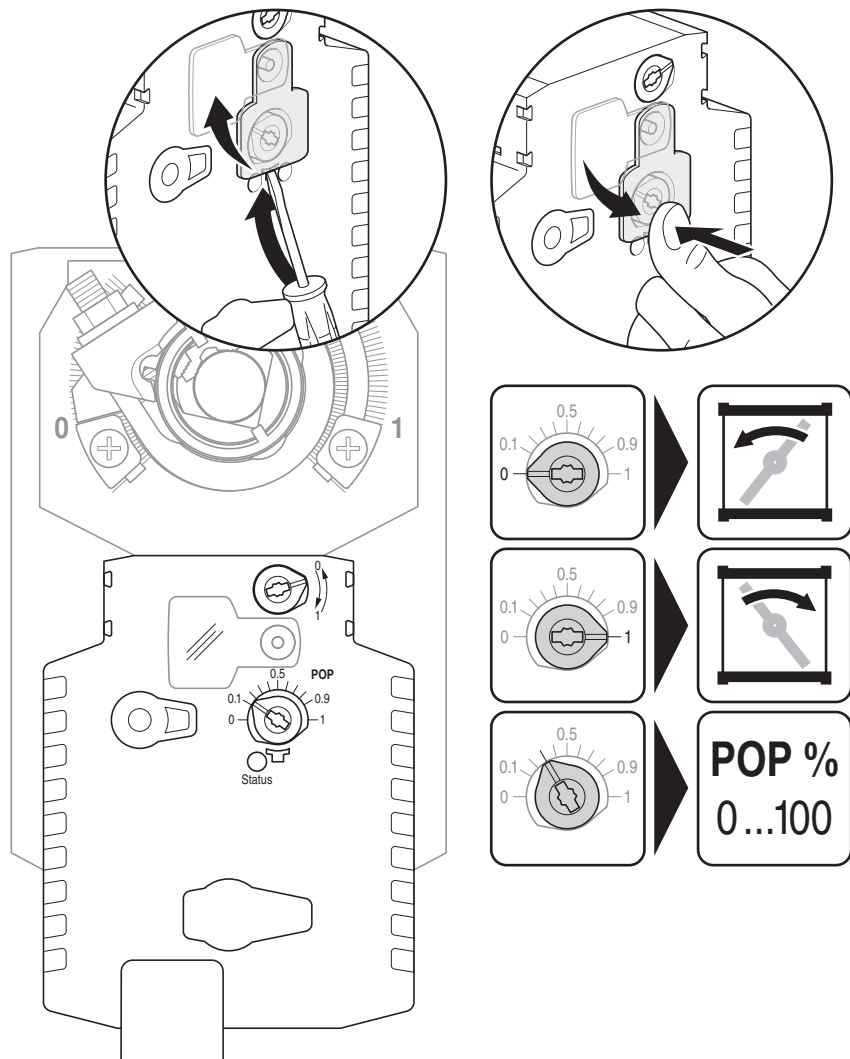

Dimensions [mm]

Dimensional drawings

Damper spindle	Length			
	16 ... 75	14 ... 26.7	≥12	≤25.5

